

Spherical Bushes

Compact and Heavy Duty flexible bearing - Spherical Bushes are able to accommodate high loads and allow movement in both the torsional and conical directions. No lubrication is required and they are completely maintenance free.



Advantages:

- High Load Capacity
- Allow Multi Axis Movement
- Reduce Stress on Assemblies
- Fail Safe Design

Applications:

- Off Road Vehicles
- Construction Equipment
- Rail applications
- Suspension Control Links
- Agricultural Equipment
- "A" frame bushes

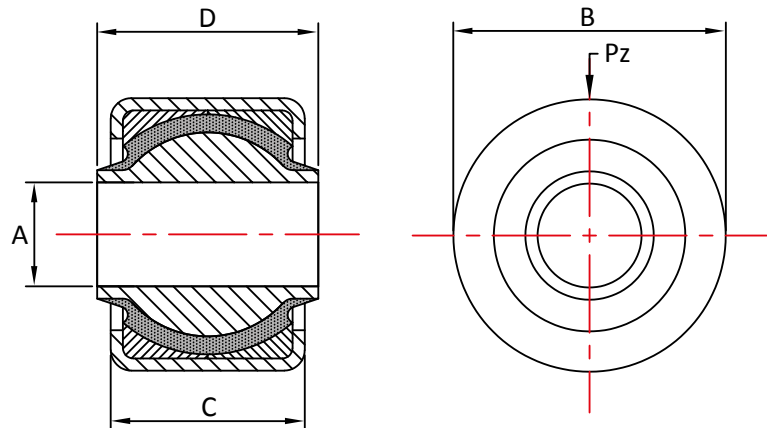

Part No	A	B	C	D	Pz (KN)
SB1316	25.4	66.7	48.0	54.2	34.0
SB2166	25.4	66.8	47.6	54.2	34.0
SB2201	25.4	66.7	47.6	54.0	34.0
SB2106	28.6	90.5	70.0	76.2	58.0
SB1285	38.1	104.8	76.2	82.6	80.0

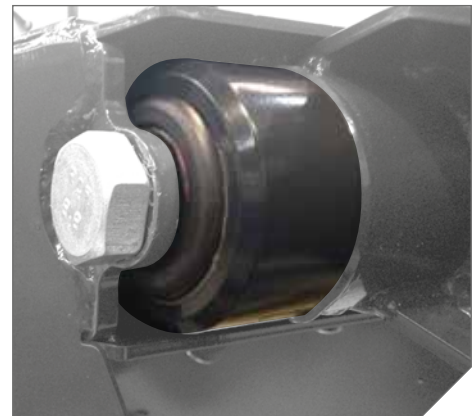

Max compression load in Kg deflection in mm.

This information is for guidance only. Customers are recommended to contact us for further technical information on products and applications. We reserve the right to alter specifications or withdraw products without notice.