

Flanged Bushes



Utilising the rubber primarily in shear, Flanged Bushes have a high radial to axial stiffness ratio and are therefore ideal for controlling horizontal movement. They are a relatively stiff mounting, suitable for carrying loads of up to 1100Kg per mounting and are ideal for high frequency vibrations. Using top and bottom washers provides a fail-safe installation.

Advantages:

- Controls Horizontal Movement
- Ideal for High Frequency Vibration
- High Load Capacity
- Fail-Safe Design

Applications:

- Engines
- Vehicles
- Radiators
- Agriculture
- Construction Equipment

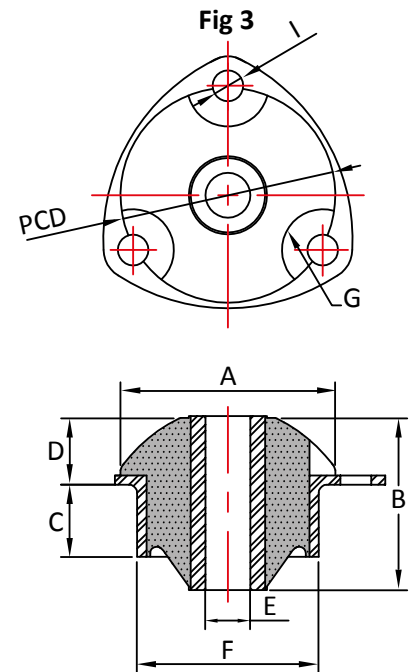
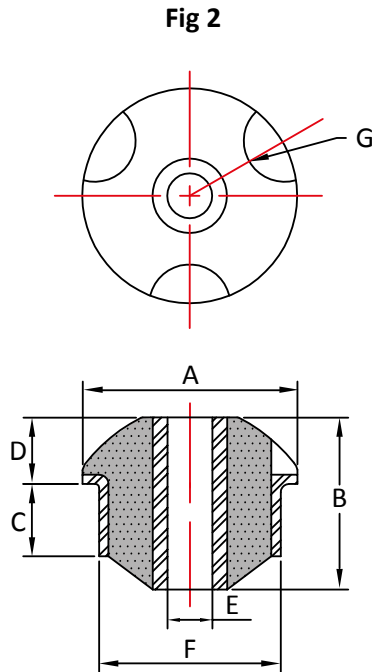
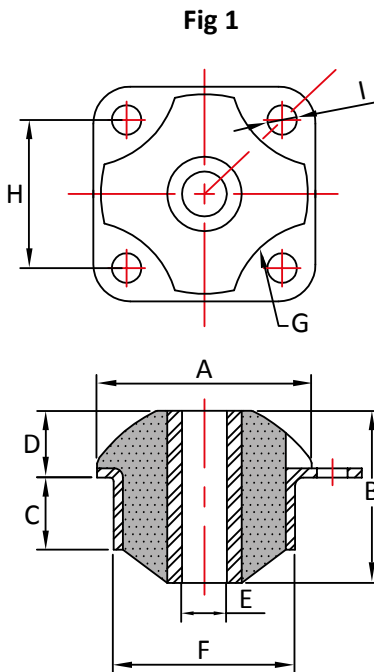

| Part No | Fig | A | B | C | D | E | F | G | H | I | PCD | 45 Shore A | | 60 Shore A | | 75 Shore A | |
|---------|-----|-----|-----|------|----|------|------|----|----|-----|-----|------------|-----|------------|-----|------------|-----|
| | | | | | | | | | | | | Kg | mm | Kg | mm | Kg | mm |
| FB00 | 1 | 36 | 28 | 12 | 11 | 8.1 | 26 | 12 | 26 | 5.2 | - | 20 | 1.5 | 30 | 1.2 | 40 | 0.8 |
| FB02 | 2 | 48 | 51 | 24 | 18 | 12.5 | 38 | 8 | - | - | - | 65 | 2.5 | 85 | 2 | 110 | 2 |
| FB20 | 2 | 70 | 55 | 27 | 19 | 18.5 | 56 | 10 | - | - | - | 100 | 3.5 | 150 | 3 | 180 | 2.5 |
| FB21 | 2 | 70 | 70 | 39 | 19 | 18.5 | 56 | 10 | - | - | - | 125 | 3.5 | 200 | 3 | 250 | 2.5 |
| FB40 | 2 | 100 | 90 | 42 | 28 | 22.5 | 74 | 19 | - | - | - | 200 | 5 | 350 | 4.5 | 400 | 3.5 |
| FB41 | 2 | 100 | 110 | 49 | 28 | 22.5 | 74 | 19 | - | - | - | 225 | 5 | 375 | 5 | 450 | 3.5 |
| FB70s | 2 | 165 | 98 | 36 | 46 | 60.2 | 119 | 22 | - | - | - | 450 | 6.5 | 800 | 5.5 | 1000 | 3.5 |
| FB70 | 2 | 165 | 140 | 66 | 46 | 60.2 | 119 | 22 | - | - | - | 450 | 6.5 | 900 | 5.5 | 1100 | 3.5 |
| FB10 | 3 | 57 | 47 | 18 | 19 | 12.1 | 49 | 11 | - | 8.2 | 69 | 70 | 4 | 100 | 3 | 120 | 2 |
| FB66 | 3 | 90 | 93 | 46.5 | 28 | 20.5 | 66.5 | 18 | - | 8.5 | 95 | 125 | 4.5 | 220 | 4 | 290 | 3.5 |

Max compression load in Kg deflection in mm.

This information is for guidance only. Customers are recommended to contact us for further technical information on products and applications. We reserve the right to alter specifications or withdraw products without notice.