

Hydro Mountings

A Unique design offering Superior Performance - Hydro Mountings combine a Rubber Element with a Hydraulic Viscous Damper in a single unit.

PROVIDES OPTIMUM ISOLATION AT NORMAL RUNNING SPEEDS

CONTROLS EXCESSIVE MOVEMENT & SHAKE AT LOW SPEEDS

The design of the rubber element & viscous pot and plunger system results in Excellent Vibration Absorption, whilst ensuring the dampening effect of the fluid only enacts when necessary (i.e. during shock forces, resonance, or when equipment is out of balance).

Hydro Mounts are particularly suited for use on Vehicle Cabs and Variable Speed Engines where the equipment may operate close to the mountings resonant frequency, such as vehicle idle speed. The viscous damper controls high amplitude "Transit movements" or "Resonance Shaking".

The mountings are manufactured with interlocking metal components to provide a failsafe design suitable for mobile applications.

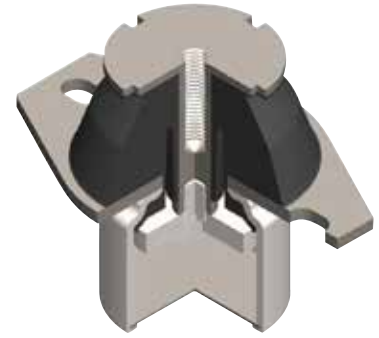

Advantages:

- Excellent Vibration Reduction – upto 95%
- Improve Operator Comfort
- Ideal for Mobile Applications
- Absorbs Transit Shocks
- ROPS & FOPS (subject to approval)

Applications:

- Cabs & Engines
- Off-Highway Vehicles
- Construction & Earthmoving Vehicles
- Agricultural Vehicles
- Variable Speed Engines



Max compression load in Kg deflection in mm.

This information is for guidance only. Customers are recommended to contact us for further technical information on products and applications. We reserve the right to alter specifications or withdraw products without notice.

Hydro Mountings

Definition of a Rubber Spring

A Rubber Spring, such as an Anti Vibration Mounting, is a mechanical device that stores energy and subsequently releases it to absorb shock and vibration. In a highly resilient polymer such as Polyisoprene (Natural Rubber) the amount of stored energy returned into the system can be as high as 97%. By creating installations with high Frequency Ratios, (i.e. the ratio between the disturbing frequency and natural frequency - f_d/f_n), high levels of vibration isolation can be achieved.

Definition of Damping

Damping is the reduction of amplitude as a result of absorption of energy, where this energy is converted and dissipated as heat. This is an extremely effective way of controlling excessive amplitudes and unwanted movement.

Damping has four common types;

1. Viscous
2. Friction
3. Hysteresis
4. Mass / Tuned

The level of Damping can be measured and quantified in various forms, all of which can be correlated with other known variants;

1. **Damping Ratio (ζ)** – The ratio between actual damping and critical damping.

$$\zeta = \frac{C}{C_c} = \frac{C}{2\sqrt{k m}}$$

2. **Damping Coefficient (C)** – A measurement of the amount of energy absorbed and is given as Force over Velocity.

$$C = \frac{\sqrt{k m}}{M}$$

3. **Loss Angle (α)** – The measurement of phase difference between the disturbing input and the response. The bigger the loss angle, the greater the damping.

$$\alpha = \tan^{-1}\left(\frac{1}{M}\right)$$

4. **Dynamic Magnifier (M)** – The magnification when the disturbing frequency coincides with the natural frequency of the mounting system (i.e Resonance). The smaller the Dynamic Magnifier the greater the damping.

$$M \text{ (at resonance)} = \frac{1}{\tan \alpha}$$

5. **Rebound Resilience (RR)** – This is the amount of energy returned from the system. The lower the resilience the greater the damping.

$$RR (\%) = e^{-\frac{\pi}{M}} \times 100$$

Max compression load in Kg deflection in mm.

This information is for guidance only. Customers are recommended to contact us for further technical information on products and applications. We reserve the right to alter specifications or withdraw products without notice.

Dynamic damping characteristics of a Hydro mount

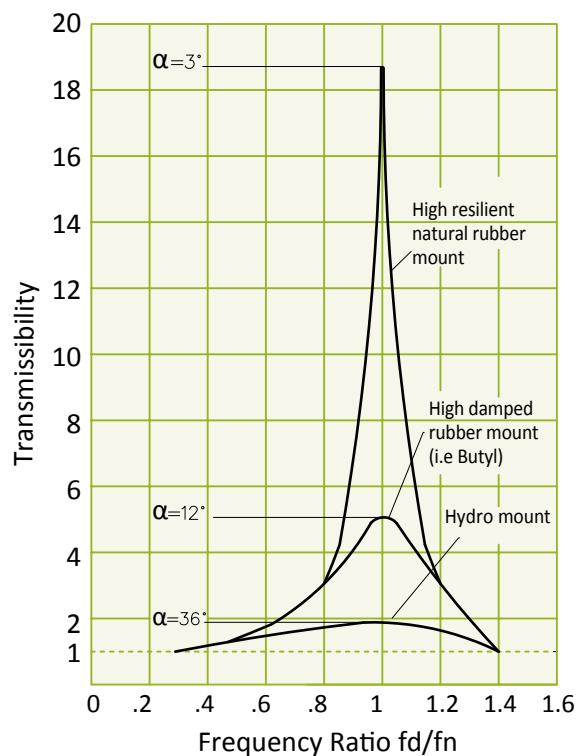
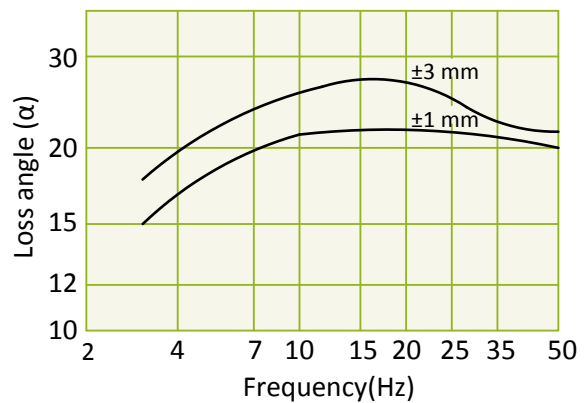

Hydro Mountings

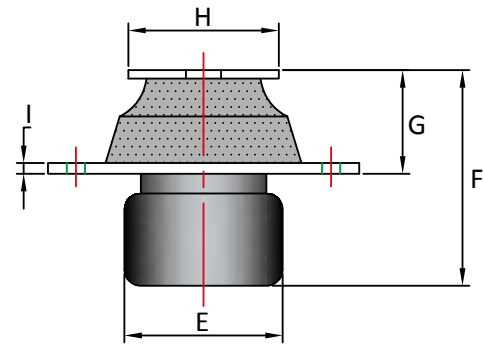
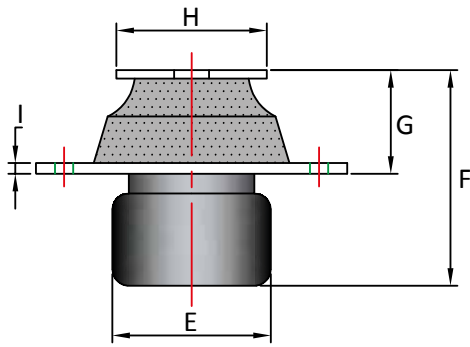

Type A (2 hole)

Type B (4 hole)

Part No	Type	A	B1	B2	L1	L2	C	E	F	G	H	I	J	K
HYDVC0.250	A	88	63	73	-	-	M10	45	60	30	30	3	56	8.2
HYDVC1.400	A	132	99	109	-	-	M10	63	86	36	45	5	90	11
HYDVC1.400SQ	B	105	64	70	79.5	82.5	M10	63	86	36	45	5	91	10
HYDVC1.500	A	132	99	109	-	-	M12	63	96	45	60	5	90	11
HYDVC1.500SQ	B	105	64	70	79.5	82.5	M12	63	96	45	60	5	91	10
HYDVC1.550	A	132	99	109	-	-	M12	63	96	45	75	5	90	11
HYDVC1.550SQ	B	105	64	70	79.5	82.5	M12	63	96	45	75	5	91	10
HYDVC3.200	A	175	130	145	-	-	M20	90	115	53	80	8	108	12
HYDVC3.200SQ	B	130	110	110	110	110	M20	90	115	53	80	8	130	12



Max compression load in Kg deflection in mm.

This information is for guidance only. Customers are recommended to contact us for further technical information on products and applications. We reserve the right to alter specifications or withdraw products without notice.

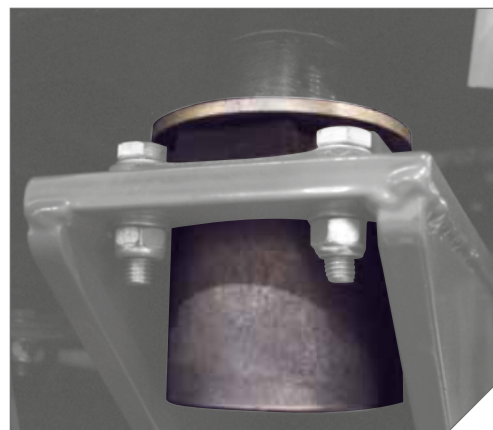
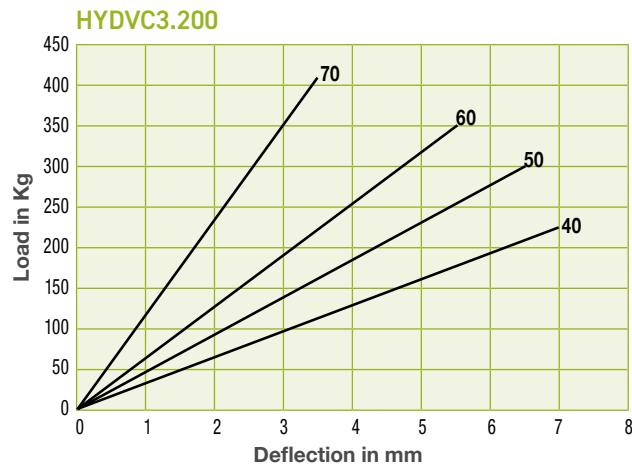
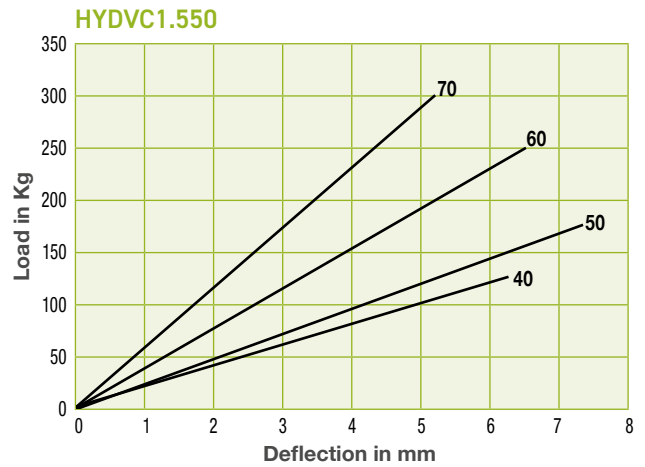
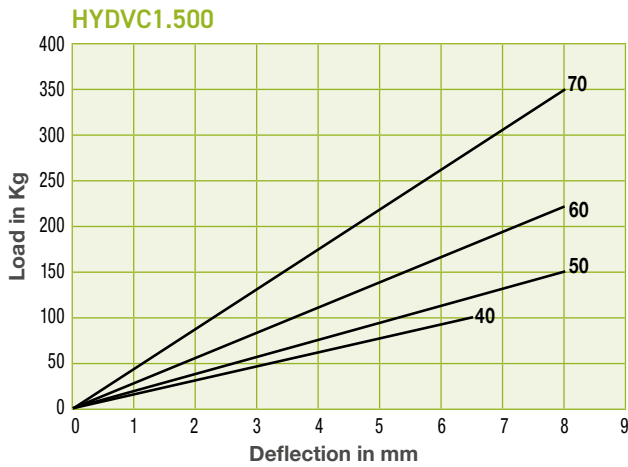
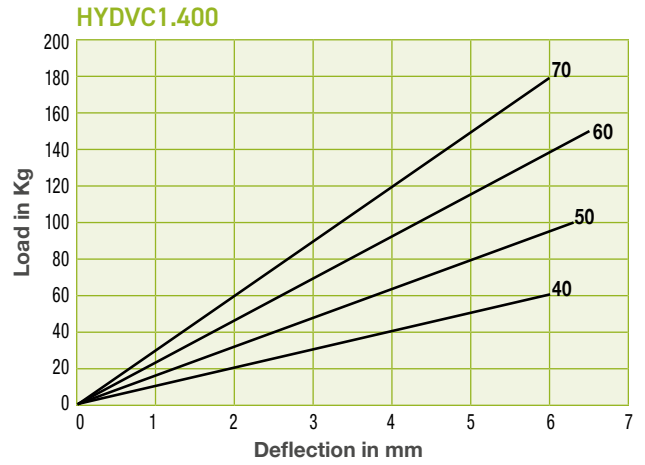
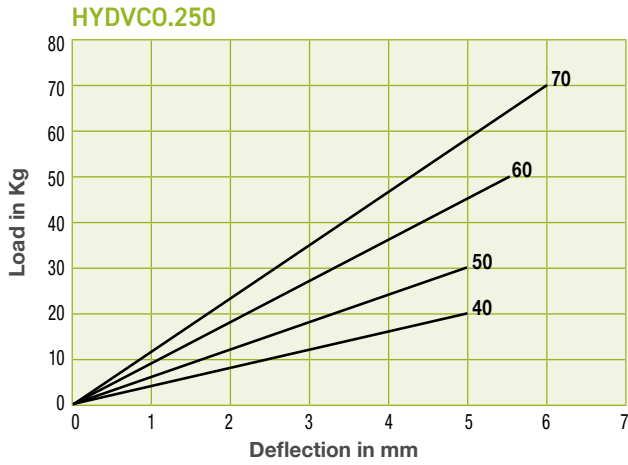

Max compression load in Kg deflection in mm.

This information is for guidance only. Customers are recommended to contact us for further technical information on products and applications. We reserve the right to alter specifications or withdraw products without notice.

Hydro Mountings

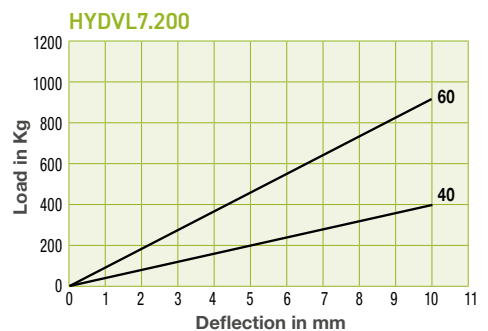
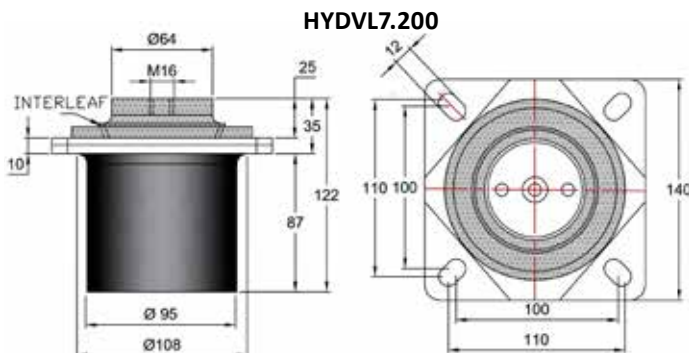
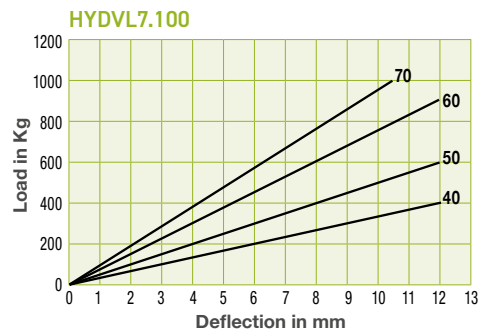
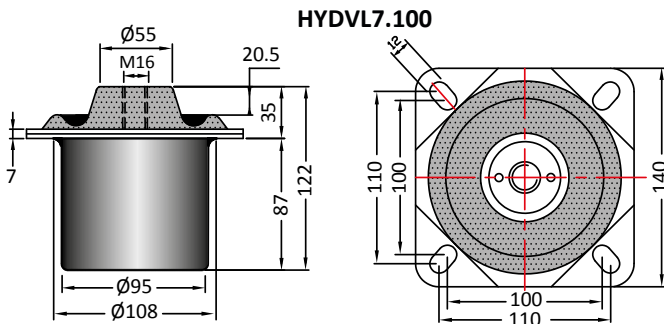
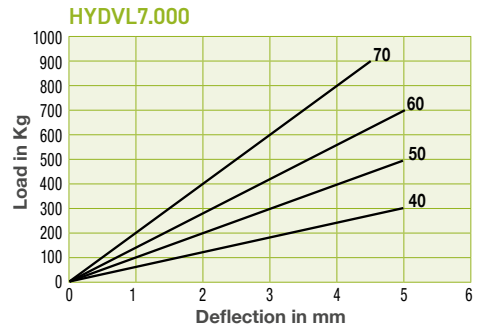
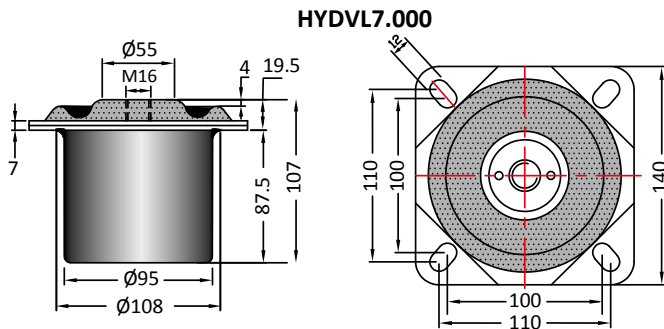
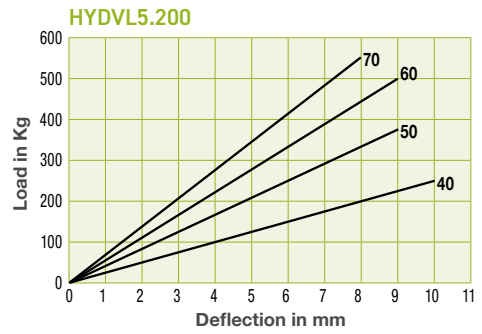
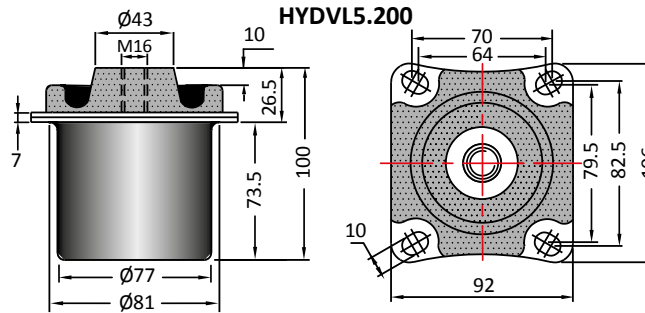
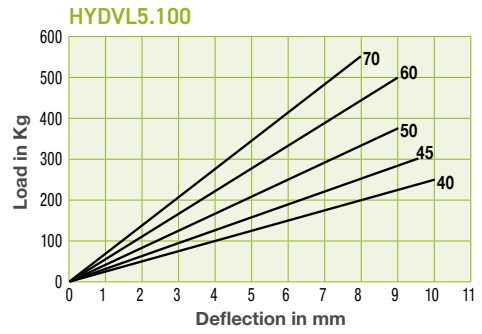
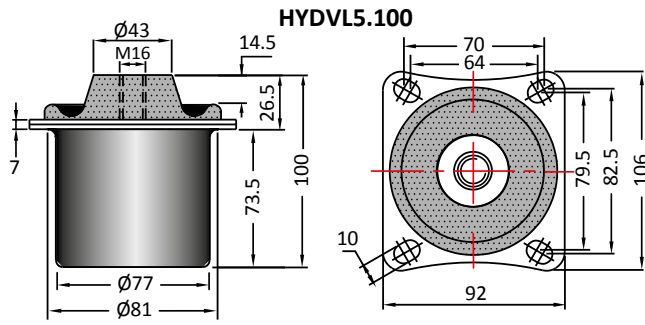

Max compression load in Kg deflection in mm.

This information is for guidance only. Customers are recommended to contact us for further technical information on products and applications.

We reserve the right to alter specifications or withdraw products without notice.

CONSTRUCTION, EARTH MOVING
AND AGRICULTURAL MACHINERY