

High Deflection Flanged Mountings



HD Flanged Mountings offer high levels of deflection, providing excellent levels of vibration reduction and shock absorption both in the vertical and horizontal planes. The metals are encapsulated in rubber to provide excellent corrosion resistance.

Advantages:

- High Deflection
- Easy to Install
- Encapsulated Metals
- Common Height throughout product range

Applications:

- Pumps
- HVAC (Fans)
- Compressors
- Shock protection

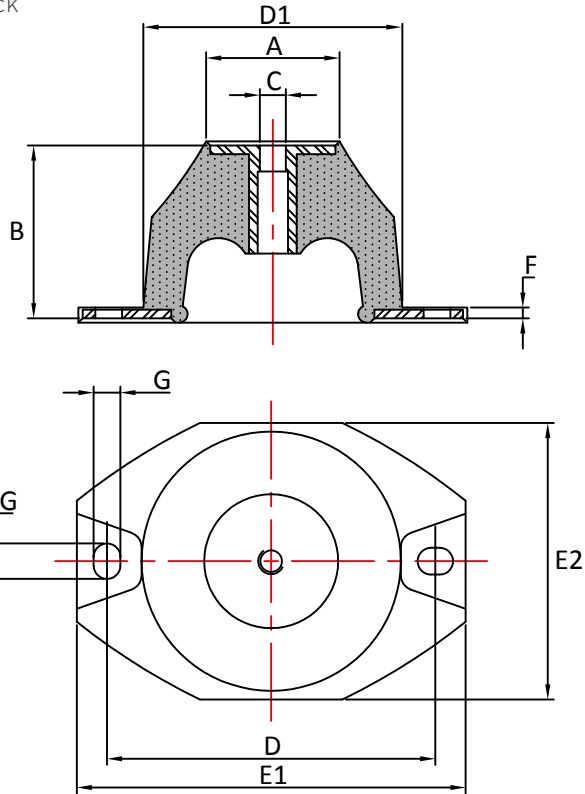

Part No	A	B	C	D	D1	E1	E2	F	G
FM4012	12	40	M6	52	40	64	44	2.5	6.2 x 6.2
FM6050	32	40	M6	76	60	90	64	2.5	8.2 x 6.2
FM80130	48	40	M8	100	80	122	84	2.5	12.2 x 8.2
FM100260	68	40	M10	124	100	152	104	3	16.2 x 10.2
FM150500	116	40	M12	182	150	214	154	4.5	20.2 x 12.2
FM2001350	159	40	M16	240	200	280	204	5.5	24.2 x 14.2

Part No	Hardness /1		Hardness /2		Hardness /3		Hardness /4	
	kg	mm	kg	mm	kg	mm	kg	mm
FM4012	4	8	7	8	12	8	15	8
FM6050	20	8	30	8	50	8	62.5	8
FM80130	70	8	100	8	130	8	162.5	8
FM100260	160	8	200	8	260	8	325	8
FM150500	325	8	400	8	500	8	625	8
FM2001350	640	8	820	8	1050	8	1350	8

Max compression load in Kg deflection in mm.

This information is for guidance only. Customers are recommended to contact us for further technical information on products and applications. We reserve the right to alter specifications or withdraw products without notice.