

Enclosed Spring Mountings

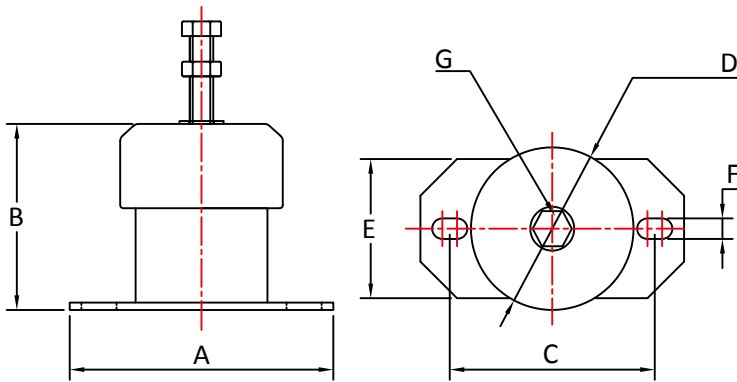

Part No	A	B	C	D	E	F	G	Max Load (kg)	Deflection (mm)
ESS20/10	76	63	54-60	48	38	6.5	M8	10	20
ESS20/15								15	20
ESS20/20								20	20
ESS20/40								40	20
ESS20/70								70	20
ESS15/100								100	15
ESM25/30	110	89	85-90	78	70	9	M10	30	25
ESM25/60								60	25
ESM25/100								100	25
ESM25/160								160	25
ESM25/250								250	25
ESL25/100	180	127	130-150	111	95	13.5	M16	100	25
ESL25/200								200	25
ESL25/300								300	25
ESL25/400								400	25
ESL25/500								500	25
ESL25/600								600	25
ESL25/700								700	25
ESL25/800								800	25
ESL25/1000								1000	25
ESL25/1200								1200	25
ESL25/1400	1400	25							

Max compression load in Kg deflection in mm.

This information is for guidance only. Customers are recommended to contact us for further technical information on products and applications. We reserve the right to alter specifications or withdraw products without notice.

Enclosed Spring Mountings Installation Instructions

The Enclosed Spring Mountings are suitable for static applications and incorporate a height adjusting device to allow the machine to be levelled during installation. Where possible mountings should be fitted on site, alternatively transit chocks should be fitted to the equipment during transportation.

The height adjusting bolts should be removed and all mountings placed in their correct floor position. The machine is now lowered into position, ensuring correct alignment of mounting fixing holes with brackets.

With lock nuts and washers fitted to the height adjusting bolts, they can now be screwed into the mounting fixing holes until a resistance is encountered.

The level of the machine can now be checked and if needed adjusted by screwing down the height adjusting bolts one or two turns at a time, in sequence at each mounting. When complete, the lock nuts should be locked in position.

If during start up or shut down the movement of the machine is considered excessive, snubbing of the movement can be increased by screwing down

the height adjusting bolts by equal amounts, one or two turns at a time, thereby raising the height of the mounting top cap which reduces the gap with the internal snubber ring.

Mountings should not be raised above their nominal unloaded height, if additional adjustment is required packing should be fitted to the top or to the bottom of the mounting.

For the mountings to isolate efficiently it is important that all connections and services to the machine should be flexible. The maximum hole size in the machine bracket should not give more than 2mm clearance on the bolt size. If the hole is larger, a suitable packing washer should be fitted below the machine bracket.

The Enclosed Spring mountings are pre-loaded during the manufacturing process and therefore have a nominal preload deflection. The deflections shown on the data sheet are "effective deflections" used for calculating the performance and percentage isolation. The actual deflection under load will be the effective deflection minus the preload.

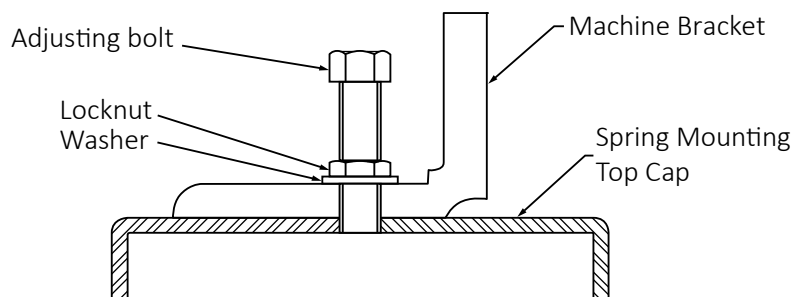

Max compression load in Kg deflection in mm.

This information is for guidance only. Customers are recommended to contact us for further technical information on products and applications. We reserve the right to alter specifications or withdraw products without notice.